

IMS-9000 Intelligent Modem Switch

USER'S MANUAL

Document Part #: RDC-HDWIMS9K100



DELPHI
DISPLAY SYSTEMS



© 2000 Delphi Display Systems, INC. All rights reserved.

Delphi Display Systems, INC. (Delphi) reserves the right to revise or update its products and documents without notification. Delphi makes no guarantee, implied or expressed regarding the suitability of its products for any particular purpose, nor does Delphi assume any liability arising out of the application of use of any of its products or circuits, whether used properly or improperly. No part of this document may be reproduced, copied or distributed without written permission from Delphi Display Systems, INC.

Delphi Display Systems, INC.
485 E. 17th Street, Suite 400
Costa Mesa, CA 92627

Contents

IMPORTANT SAFETY INSTRUCTIONS	4
INTRODUCTION	5
PARTS CHECK LIST	5
FRONT PANEL LAYOUT	5
<i>Front Panel LED Indicators</i>	6
<i>Push Buttons</i>	7
CONNECTOR LAYOUT	7
<i>PC Connector – DB9F</i>	8
<i>Telephone Connectors – RJ11</i>	8
<i>POS Connector</i>	8
<i>Power Input Connector</i>	8
<i>OCS Connector</i>	8
SYSTEM CONNECTION DIAGRAM	9
INSTALLATION.....	9
LOCATION	9
TYPICAL INSTALLATION	9
TESTING THE IMS9000	10
SOFTWARE INSTALLATION	11
MODES OF OPERATION.....	11
POWER OFF MODE.....	11
POWER UP SEQUENCE	11
AUTOMATIC MODE.....	11
<i>MODEM Connection Request</i>	11
<i>PC Connection Request</i>	12
MANUAL MODE.....	12
<i>Manual Mode 1 – OCS ↔ POS, PC ↔ MODEM</i>	12
<i>Manual Mode 2 – OCS ↔ MODEM, POS ↔ PC</i>	13
<i>Manual Mode 3 – OCS ↔ PC, POS ↔ MODEM</i>	13
MAINTENANCE.....	13
IN CASE OF DIFFICULTY	14
STANDARD LIMITED WARRANTY	15
IMS9000 TECHNICAL SPECIFICATIONS.....	16
AC POWER ADAPTER	16
IMS9000 UNIT	16
AGENCY APPROVALS	16
FCC COMPLIANCE STATEMENT	16
TECHNICAL SUPPORT	16

List of Figures

FIGURE 1 - FRONT PANEL LAYOUT.....	5
FIGURE 2 - CONNECTOR LAYOUT.....	7
FIGURE 3 - SYSTEM CONNECTION DIAGRAM	9
FIGURE 4 - REAR PANEL LAYOUT	10
FIGURE 5 - DEFAULT CONNECTION INDICATORS (AUTOMATIC MODE).....	11
FIGURE 6 - MODEM/OCS CONNECTION INDICATORS (AUTOMATIC MODE).....	12
FIGURE 7 - MANUAL MODE 1 INDICATORS	12
FIGURE 8 - MANUAL MODE 2 INDICATORS	13
FIGURE 9 - MANUAL MODE 3 INDICATORS	13

Important Safety Instructions

When using your IMS9000 Intelligent Modem Switch product, the following safety precautions should be followed to reduce the risk of fire, electric shock and personal injury.

- Read and understand all instructions.
- Follow all warnings and instructions marked on the product.
- Do not spill liquid on this product.
- Unplug the product from the wall outlet before cleaning. Do not use liquid or aerosol cleaners. Use a damp clean cloth when cleaning.
- This product should be operated only from the type of power source indicated on the rear panel label.
- Do not overload wall outlets and extension cords as this can result in the risk of fire or electric shock.
- Refer all servicing of this product to a Delphi authorized service facility.

SAVE THESE INSTRUCTIONS

Introduction

Congratulations on your purchase of the IMS9000 Intelligent Modem Switch. The IMS9000 has been designed to work with your Delphi Drive-Thru Order Confirmation System (OCS) *also known as Customer Order Display (COD) and Order Confirmation Board (OCB)*. It allows you to remotely update your OCS configuration, daypart, and graphic files via standard dial up access. In addition, the IMS9000 functions as a diagnostic tool for quickly troubleshooting Point of Sale, OCS or cabling problems in the restaurant.

This manual is designed to familiarize you with the IMS9000 features and operation. We strongly recommend you read the manual before installing or using this product.

Parts Check List

The following parts are included with your IMS9000 product. If anything is missing, please contact Delphi Display Systems at the number listed in the back of this manual for replacement parts.

1. IMS9000 Unit
2. AC Power Adapter
3. Telephone Cord
4. Wall Mounting Hardware (2 ea. #8 screws, 2 ea. wall anchors)
5. User's Manual
6. Configuration Tool Software CD and Documentation

Front Panel Layout

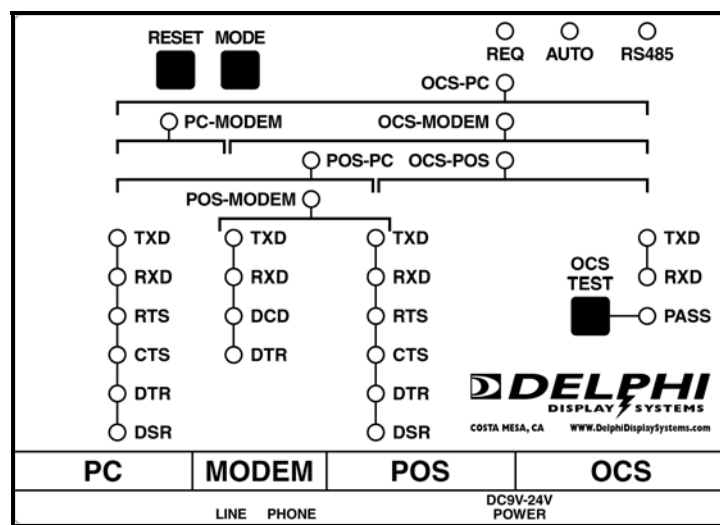

Figure 1 - Front Panel Layout

Front Panel LED Indicators

The front panel indicators are organized into five groups. The functions of each group are described in the following sections.

Mode Indicator LEDs

The Mode Indicator LEDs are used to determine the various modes of operation.

LED Indicator	Function
REQ	Flashes when a mode change request is made. A mode change request can come from the MODEM (call answer or hang up), or from an external PC connected to the PC port connection.
AUTO	Flashes in a heart beat pattern during Automatic mode of operation. This is the default mode of operation after power-up or reset.
RS485	When ON, indicates the OCS interface is in RS485 mode. When off, the OCS interface is in RS232 mode. This mode is set via a jumper on the IMS9000 circuit board.
OCS-PC	Indicates the OCS is connected to the PC port.
PC-MODEM	Indicates the PC port is connected to the MODEM.
OCS-MODEM	Indicates the OCS is connected to the MODEM.
POS-PC	Indicates the POS is connected to the PC port.
OCS-POS	Indicates the OCS is connected to the POS port. This is the default mode of operation after power-up or reset.
POS-MODEM	Indicates the POS port is connected to the MODEM.

Table 1 – Mode Indicator LEDs

PC Status LED Indicators

These LED indicators provide information on the activity over the PC RS232 communications port.

LED Indicator	Function
TXD	Transmit Data.
RXD	Receive Data.
RTS	Request to Send.
CTS	Clear to Send.
DTR	Data Terminal Ready.
DSR	Data Set Ready.

Table 2 - PC Status LEDs

Modem Status LED Indicators

LED Indicator	Function
TXD	Transmit Data.
RXD	Receive Data.
DCD	Data Carrier Detect. This LED is illuminated when a telephone connection is established and remains illuminated until the connection is dropped.
DTR	Data Terminal Ready.

Table 3 - MODEM Status LEDs

POS Status LED Indicators

LED Indicator	Function
TXD	Transmit Data.
RXD	Receive Data.
RTS	Request to Send.
CTS	Clear to Send.
DTR	Data Terminal Ready.
DSR	Data Set Ready.

Table 4 - POS Status LEDs

OCS Status LED Indicators

LED Indicator	Function
TXD	Transmit Data. This LED flashes when data is transmitted to the OCS.
RXD	Receive Data. This LED flashes when data is received from the OCS.
PASS	OCS Test Status Indicator. GREEN indicates Pass, RED indicates Fail.

Table 5 - OCS Status LEDs

Push Buttons

There are three (3) push buttons on the front panel of the IMS9000.

RESET

The RESET push button resets the IMS9000 and puts it into its power-up condition. Any telephone connections are immediately dropped and the unit returns to Automatic mode of operation (POS connected to the OCS).

MODE

The MODE switch manually cycles through each mode of operation. Each time the button is pressed, the IMS9000 advances to the next mode until it returns to Automatic mode.

OCS TEST

The OCS TEST button performs a self-test of the OCS when it is connected. The results of the self-test are displayed on the PASS LED indicator. Green indicates PASS and Red indicates FAIL.

Connector Layout

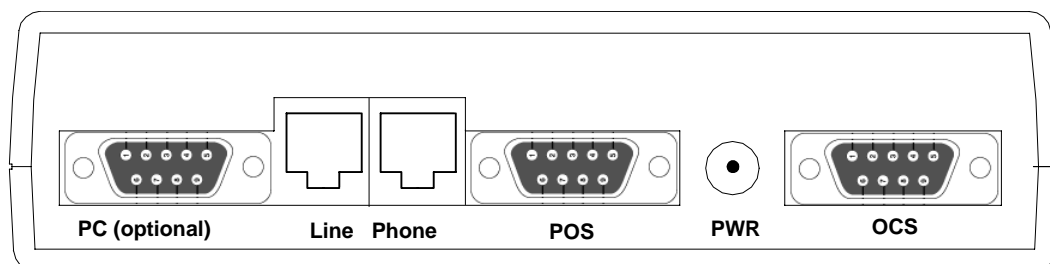

Figure 2 - Connector Layout

PC Connector – DB9F

The PC connector allows a direct connection to a PC serial communication port via a standard straight-through wired serial extension cable.

Telephone Connectors – RJ11

CAUTION: TO REDUCE THE RISK OF FIRE, USE NO.26AWG OR LARGER TELECOMMUNICATION LINE CORD.

Line

The Line connector is used to connect the IMS9000 to the telephone line via a standard telephone cord (supplied).

Phone

This Phone connector allows a telephone, fax, or other telecom device access to the telephone line when the IMS9000 internal modem is not being used.

Note: *The IMS9000 is preset at the factory to answer on the 4th ring.*

POS Connector

The POS connector allows a direct connection to the Point Of Sale terminal serial communication port via a standard straight-through wired serial extension cable.

Power Input Connector

The Power Input connector accepts power from the AC Power Adapter (supplied).

CAUTION: ONLY USE THE AC POWER ADAPTER PROVIDED WITH YOUR IMS9000.

OCS Connector

The Order Confirmation System is connected to the OCS connector using the serial I/O cable supplied with the OCS equipment. The I/O cable is terminated with a female DB9 connector. The OCS connector supports both RS232C and RS422 serial communication standards and is optically isolated to protect all connected equipment.

System Connection Diagram

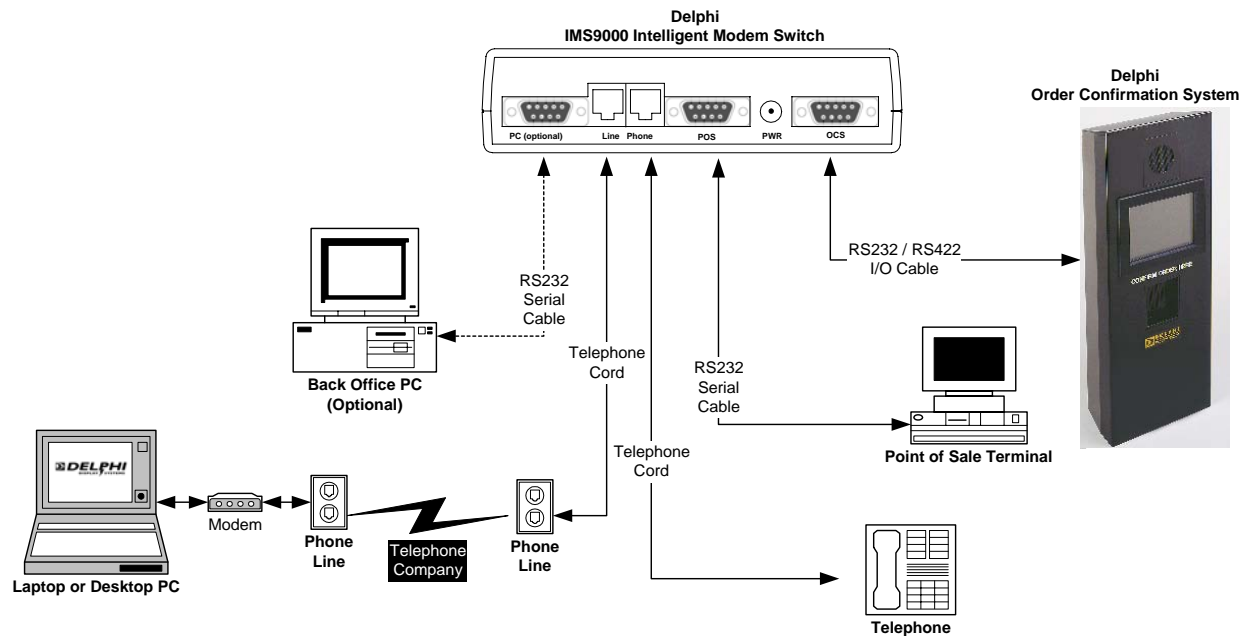

Figure 3 - System Connection Diagram

Installation

Unpack your IMS9000 and verify that all of the contents listed in the Parts Check List section are accounted for. If any parts are missing, please contact Delphi Display Systems at the number listed in the back of this manual for replacement parts.

Location

The IMS9000 is designed to be wall mounted in the back office of the store. Choose a location that meets the following requirements:

- The front panel indicators are easily visible and can be observed at all times.
- The mounting location is within six (6) feet of an AC power outlet.
- The mounting location is in close proximity to the telephone (modem) line to be connected to the IMS9000.

Typical Installation

1. Mark the locations of the two (2) mounting screw holes on the wall in the desired location at exactly 3.50" on center. Refer to the *Rear Panel Layout* figure below.
2. Drill two pilot holes and install the two #8 screws provided. Allow each screw to protrude from the wall approximately 1/8" so that it will lock into the rear panel keyholes of the IMS9000. *In locations where installing to drywall, use the supplied anchors if necessary. To install anchors, drill two 1/4" holes and insert the anchors flush to the wall surface.*

3. Install the IMS9000 over the two screws and adjust the screws as necessary to obtain a secure fit.
4. Connect the DB9 Female connector on the end of the OCS Serial I/O Cable to the OCS connector on the IMS9000. Secure with the screws provided on the cable connector.
5. Connect the DB9 Male connector of the Point of Sale serial extension cable to the POS connector on the IMS9000. Secure with the screws provided on the cable connector.
6. If a connection to the back office PC or laptop computer is desired, connect the serial extension cable to the PC connector on the IMS9000. Secure with the screws provided on the cable connector.
7. Connect one end of the Phone Cord (provided) to the LINE connector on the IMS9000. Connect the other end to the phone jack in the back office. A fax machine or telephone may be connected to the PHONE connector if desired.
8. Plug the AC Power Supply cord into the Power connector of the IMS9000 and plug into an AC Power Outlet.
9. Secure all cables with ties and strain reliefs to prevent accidental disconnection or damage.

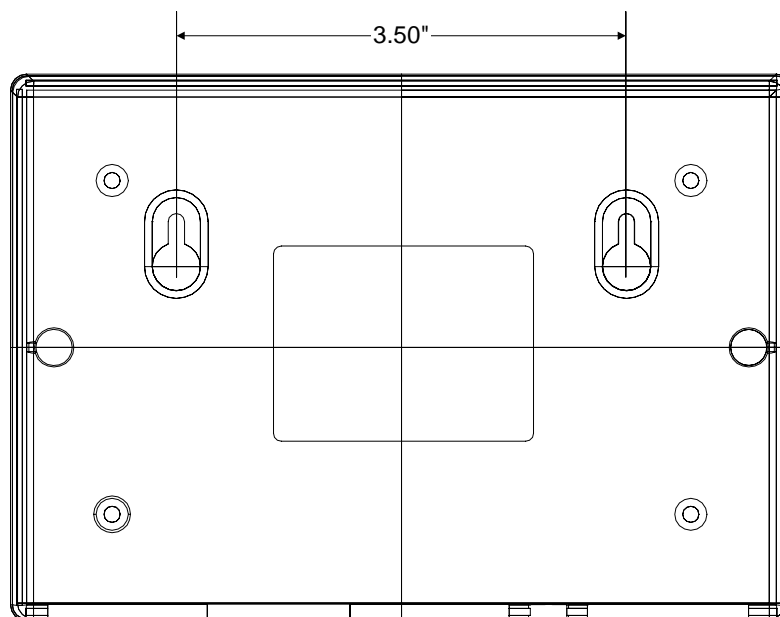

Figure 4 - Rear Panel Layout

Testing the IMS9000

Upon applying power to the IMS9000, verify that the front panel indicators briefly illuminate and the AUTO indicator begins to flash in a *heart beat* mode. Refer to the *Power Up Sequence* section for additional details.

Software Installation

Please refer to the documentation included with the software CD for installation and user instructions.

Modes of Operation

Power Off Mode

The IMS9000 is designed to provide uninterrupted operation in the event of a loss of power. If the IMS9000 loses power, it will connect the POS directly to the OCS so that orders can be processed normally without interruption. This only applies to RS232 OCS configurations.

Power Up Sequence

When power is applied to the IMS9000, the front panel indicators will perform the following functions:

- REQ, AUTO, and other mode indicators will rapidly flash for a few seconds.
- The AUTO indicator will then commence its heart beat flash pattern and the POS-OCS indicator will turn on indicating the unit is in Automatic mode.

Automatic Mode

In Automatic mode, the IMS9000 continually monitors requests from the PC and MODEM communication ports. If a request comes in over one of these ports, the internal micro-controller will break the OCS-POS connection and establish a new connection with the requesting device. The connection will remain in effect until it is dropped or disconnected. At that time, the IMS9000 will default back to the OCS-POS connection until the next request is processed.

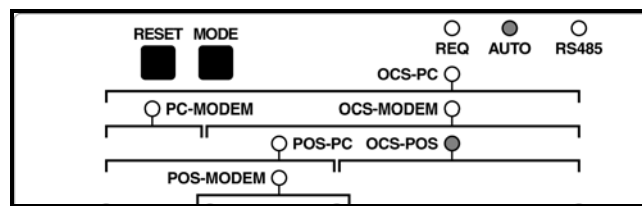

Figure 5 - Default Connection Indicators (Automatic Mode)

MODEM Connection Request

In Automatic mode, the IMS9000 will automatically answer incoming calls from a remote PC on the LINE connection after four (4) rings. The remote PC must be running Delphi's OCS Configuration Tool software to be properly authenticated. When the authentication process is complete, the OCS-POS connection is broken and the OCS-MODEM connection is established. The remote PC can then perform OCS maintenance functions such as changing dayparts, downloading graphic and video files, upgrading system software, etc. When the modem connection is dropped or the remote PC hangs

up, the IMS9000 restores the OCS-POS connection allowing normal operation to resume.

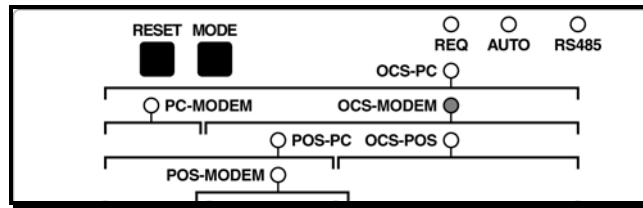

Figure 6 - Modem/OCS Connection Indicators (Automatic Mode)

PC Connection Request

In Automatic mode, a local back office or laptop PC can make a request for a direct connection to the OCS. The remote PC must be connected to the IMS9000 PC port connector via a RS232 serial data cable and be running Delphi's OCS Configuration Tool software to be properly authenticated. When the authentication process is complete, the OCS-POS connection is broken and the OCS-PC connection is established. The local PC can then perform OCS maintenance functions such as changing dayparts, downloading graphic and video files, upgrading system software, etc. When the local PC connection is disconnected, the IMS9000 restores the OCS-POS connection allowing normal operation to resume.

Manual Mode

The IMS9000 features a MODE switch that allows you to manually change the current mode of operation. Whenever the MODE switch button is pushed, the IMS9000 will cycle through the following stages.

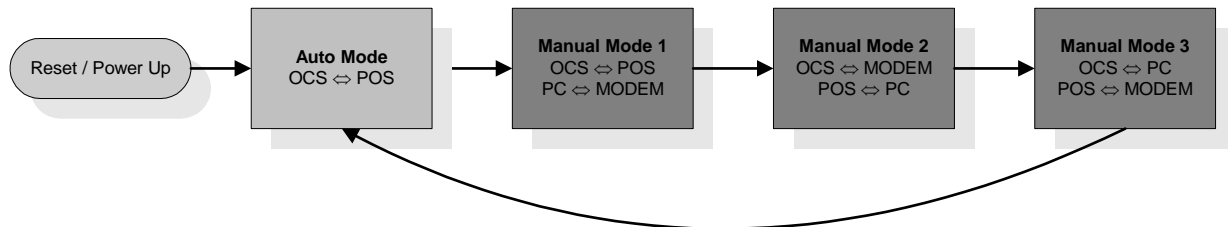

Manual Mode 1 – OCS ↔ POS, PC ↔ MODEM

Communication is established between the OCS and the Point Of Sale (POS) terminal as well as between the PC and the MODEM port.

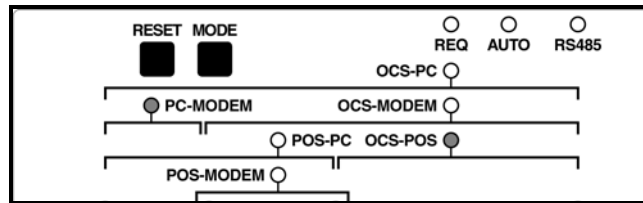

Figure 7 - Manual Mode 1 Indicators

Manual Mode 2 – OCS ↔ MODEM, POS ↔ PC

Communication is established between the OCS and the MODEM as well as between the Point Of Sale (POS) terminal and the PC port.

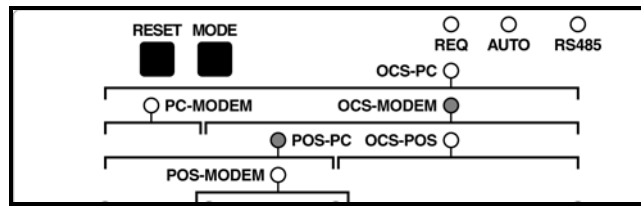

Figure 8 - Manual Mode 2 Indicators

Manual Mode 3 – OCS ↔ PC, POS ↔ MODEM

Communication is established between the OCS and the PC port as well as between the Point Of Sale (POS) terminal and the MODEM port.

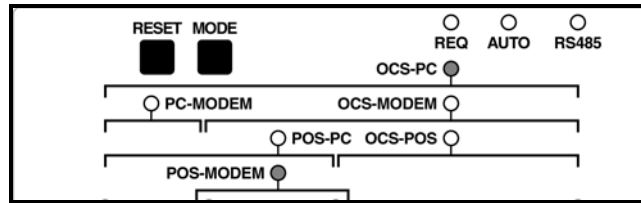

Figure 9 - Manual Mode 3 Indicators

Maintenance

Your IMS-9000 has a durable plastic case that should retain its luster for many years. Clean only with a soft clean cloth slightly dampened with water or a mild soap. Do not use excess water or cleaning solvents of any kind.

In Case of Difficulty

If you have difficulty, refer to the following table for solutions to some common problems. If you continue to have difficulty, contact Delphi Display Systems technical support.

PROBLEM	POSSIBLE CAUSE(S)	CORRECTIVE ACTION(S)
No LED indicators are active on the IMS9000	No Power to the IMS9000	Make sure the AC Power Adapter is plugged into a live AC outlet and that the power connector is properly plugged into the power jack on the IMS9000.
	Defective AC Power Adapter or IMS9000 unit.	Contact Delphi Customer Support.
Some (or all) of the LED indicators for the POS and PC ports are active, however no other indicators are active.	No Power to the IMS9000	Make sure the AC Power Adapter is plugged into a live AC outlet and that the power connector is properly plugged into the power jack on the IMS9000.
	Defective AC Power Adapter or IMS9000 unit.	Contact Delphi Customer Support.
The IMS9000 does not answer incoming phone calls.	Bad phone connection to the IMS9000.	Check the RJ-11 (phone line) connector – the connector should be connected with the plastic tab towards the front panel of the IMS9000.
	Bad phone connection or inactive phone line at the wall connection.	Check the phone cable connection at your location.
	Another device on the line (FAX or Modem) is picking up the call before the IMS9000 answers on the 4 th ring.	Temporarily disconnect (or power down) the other device while using the IMS9000.
The IMS9000 will not establish communication properly over the serial (direct) connections using a local PC connected to the IMS9000 PC port.	Bad serial connections between the local PC and the IMS9000.	Check the serial connectors on both ends of the cable, reassure they are secure in place. Make sure the IMS900 is in the proper mode.

STANDARD LIMITED WARRANTY

Delphi Display Systems, INC. ("Delphi") warrants this Product against defects in material or workmanship as follows:

Limited Warranty

LABOR: For a period of twelve (12) months from the date of purchase, if this Product is determined to be defective, Delphi will repair or replace the product with a new or rebuilt unit at no charge, or pay the labor charges to any Delphi authorized service facility. After the Warranty Period, the customer is responsible for all labor charges.

PARTS: In addition, Delphi will supply, at no charge, new or rebuilt replacements in exchange for defective parts for a period of twelve (12) months. After the Warranty Period, the customer is responsible for all parts costs.

WARRANTY SERVICE: If the product proves defective due to physical defects that were present when the product was manufactured, it may be repaired or replaced at Delphi's option. When returning a product, obtain a Return Material Authorization (RMA) number from Delphi. Repaired or replaced products will be shipped via standard UPS ground shipping, any other method of shipping will be paid by the customer.

This limited warranty applies in the United States and Canada to hardware and software products manufactured by Delphi Engineering Group, Inc

This limited warranty does not extend to any product that has been damaged or rendered defective (a) as a result of accident misuse, or abuse; (b) as a result of an act of god; (c) by the use of parts not manufactured or sold by Delphi; (d) by modification of the product. Delphi is not responsible for damage to or loss of any programs or data.

IN NO EVENT SHALL DELPHI'S LIABILITY EXCEED THE PRICE PAID FOR THE PRODUCT FROM DIRECT, INDIRECT, SPECIAL, INCIDENTAL, OR CONSEQUENTIAL DAMAGES RESULTING FROM THE USE OF THE PRODUCT, ITS ACCOMPANYING SOFTWARE, OR ITS DOCUMENTATION.

EXCEPT AS EXPRESSLY SET FORTH IN THIS WARRANTY, DELPHI MAKES NO OTHER WARRANTIES, EXPRESSED OR IMPLIED, INCLUDING ANY IMPLIED WARRANTIES OF MERCHANTABILITY AND FITNESS FOR A PARTICULAR PURPOSE. DELPHI EXPRESSLY DISCLAIMS ALL WARRANTIES NOT STATED IN THIS LIMITED WARRANTY. ANY IMPLIED WARRANTIES THAT MAY BE IMPOSED BY LAW ARE LIMITED TO THE TERMS OF THIS EXPRESS LIMITED WARRANTY.

Limitation of Remedy

Delphi is not liable for any damages caused by the Product or the failure of the Product to perform, including any lost profits, lost savings, incidental damages, or consequential damages. Delphi is not liable for any claim made by a third party.

This limitation applies whether damages are sought, or a claim made, under this Warranty or as a tort claim (including negligence and strict product liability), a contract claim, or any other claim. This limitation cannot be waived or amended by any person. This limitation of liability will be effective even if Delphi or an authorized representative of Delphi has been advised of the possibility of any such damages.

Extended Warranty Option

This Standard Limited Warranty may be extended beyond twelve (12) months for an additional twenty-four (24) months for \$90.00. This Extended Warranty must be paid for within thirty (30) days of the installation of the product.

USA State Laws

Some states do not allow limitation on how long an implied warranty lasts. In such states, the limitation or exclusions of this Limited Warranty may not apply.

Delphi reserves the right to revise or update its products, software, or documentation without obligation to notify any individual or entity. Please direct all inquiries to:

**Delphi Display Systems, INC.
485 E. 17th Street, Suite 400
Costa Mesa, CA 92627
Phone: (949) 515-1490
Fax: (949) 515-1491**

IMS9000 Technical Specifications

AC Power Adapter

- Input Voltage: 120 VAC
- Frequency: 60 Hz.
- Power: 8W

IMS9000 Unit

- Input Voltage: 8-24 VDC or 15-24 VAC
- Modem V.34 / V.32 bis (33.6 kbps)
- Serial Interfaces:
 - PC RS-232C, DB9F
 - Phone / Line Std. Telco, RJ11
 - POS RS-232C, DB9F
 - OCS RS-232C, RS-422/RS-485, DB9M (Optically Isolated)
- Operating Temperatures: 50° to 120° F (ambient)
- Dimensions: 6.125 "W X 1.5"H X 4.25"D
- Weight: 10.9 oz.

Agency Approvals

- FCC Part 15, 68
- UL #E154563 (USA and Canada)
- CE

**SPECIFICATIONS ARE TYPICAL AND MAY CHANGE
WITHOUT NOTICE**

FCC Compliance Statement

This equipment complies with Part 15 of the Federal Communications Commission (FCC) rules for the United States. Operation is subject to the following two conditions: (1) this device may not cause interference, and (2) this device must accept any interference, including interference that may cause undesired operation of the device.

Technical Support

Delphi Display Systems, INC
485 E. 17th Street, Suite 400
Costa Mesa, CA 92627
Phone: 1-800-456-0060
www.DelphiDisplaySystems.com